

Activity P26: Centripetal Force on a Pendulum (Force Sensor, Photogate)

Concept	<i>DataStudio</i>
Centripetal force	P26 Centripetal Force.DS

Equipment Needed	Qty	Equipment Needed	Qty
Economy Force Sensor (CI-6746)	1	Clamp, right angle (SE-9444)	2
Photogate (ME-9204B)	1	Mass and Hanger Set (ME-8967)	1
Balance (SE-8723)	1	Pendulum bob	1
Base and Support Rod (ME-9355)	1	String (SE-8050)	1 m
Calipers (SF-8711)	1	Support Rod (ME-8736)	1

What Do You Think?

What are the factors that affect the centripetal force on a pendulum bob as the pendulum swings back and forth? Does the centripetal force depend on how fast the pendulum bob is swinging?



Take time to answer the 'What Do You Think?' question(s) in the Lab Report section.

Background

A pendulum bob follows a circular path. Therefore, it is acted on by a centripetal (“center-seeking”) force. In the case of the pendulum, the tension in the string causes the bob to follow the circular path. At the bottom of the pendulum’s swing the net force on the bob is the combination of the tension in the string and the force due to gravity.

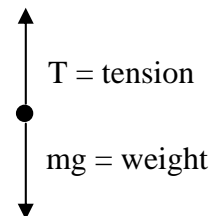

From Newton’s Second Law, $\Sigma F = T - mg = ma = F_c$

where T is the tension in the string, m is the mass of the pendulum bob, g is the acceleration due to gravity, and F_c is the centripetal force.

The Force Sensor will be zeroed when the pendulum is at rest in its equilibrium position (when $T = mg$). Thus the force measured by the Force Sensor when the pendulum passes through the lowest point of the swing is equal to the centripetal force F_c .

The centripetal force can also be found using the speed, v , of the bob as it passes through the lowest point of the swing using:

$$F_c = m \frac{v^2}{r}$$

where r is the radius of the circular path which, in this case, is equal to the length of the pendulum.

SAFETY REMINDER

- Follow the directions for using the equipment.

THINK SAFETY
ACT SAFELY
BE SAFE!

For You To Do

Use the Force Sensor to measure the centripetal force on a pendulum bob at the lowest point of its swing. Use the Photogate to measure the time that the pendulum bob blocks the Photogate beam. Enter the value for the diameter of the pendulum bob. For the bottom of the pendulum swing, *DataStudio* calculates and displays the speed of the pendulum bob and the centripetal force on the pendulum.

PART I: Computer Setup

1. Connect the *ScienceWorkshop* interface to the computer, turn on the interface, and turn on the computer.
2. Connect the Photogate’s phone plug to Digital Channel 1.
3. Connect the DIN plug of the Force Sensor to Analog Channel A.
4. Open the document titled as shown:

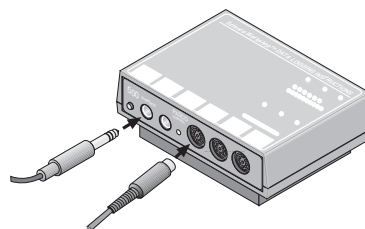

<i>DataStudio</i>		
P26 Centripetal Force.DS		

- The *DataStudio* document has a Workbook display. Read the instructions in the Workbook.
- Data recording is set at 100 Hz for the Force Sensor.

PART II: Sensor Calibration and Equipment Setup

- You do not need to calibrate the Photogate.
 - To calibrate the Force Sensor, refer to the description in the Force Sensor Manual.
1. Measure the value of the diameter of the pendulum bob. Record the diameter in the Data Table in the Lab Report section.
 2. Enter the diameter into the software.

- In *DataStudio*, double click on the Vel calculation in the Summary Window. The Calculator window will open. The window shows the calculation for velocity.

The pendulum width is stored as an ‘Experiment Constant’. If the diameter for the pendulum is different than the value listed, highlight the width value in the ‘Value’ window and type in diameter of the pendulum.

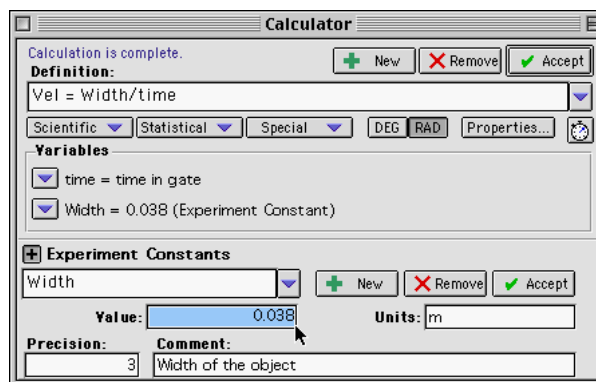

Click the ‘Accept’ button to save your change.

Close the Experiment Calculator window.

3. Mount the Force Sensor on a horizontal rod with the hook end down.
 4. Measure the mass of the pendulum bob. Record the mass in the Data Table in the Lab Report section.
 5. To make the pendulum, use a piece of string that is about one meter long. Tie one end of the string to the hook on the Force Sensor and tie the other end to the pendulum bob.
 6. Arrange the Photogate so the pendulum bob blocks the Photogate's beam when the bob is at rest. The center of mass of the pendulum bob should be approximately at the same height as the Photogate beam.
 7. Measure the length of the pendulum from the bottom of the Force Sensor's hook to the middle of the pendulum bob. Record the length of the pendulum in the Data Table.
- Practice swinging the pendulum bob. Pull the pendulum bob to the side about 15 to 20 centimeters. Gently release the bob so it swings through the Photogate as smoothly as possible. The middle of the pendulum should break the photogate beam. Adjust the position of the Photogate if necessary.
 - Do not let the pendulum bob hit the Photogate.

PART III: Data Recording

1. When the pendulum bob is at rest, zero the Force Sensor by pressing the tare button.
2. Set the pendulum in motion. Let the pendulum swing back-and-forth several times to allow any oscillations to damp out.
3. Begin recording data.
4. Record data for about 20 seconds. End data recording.

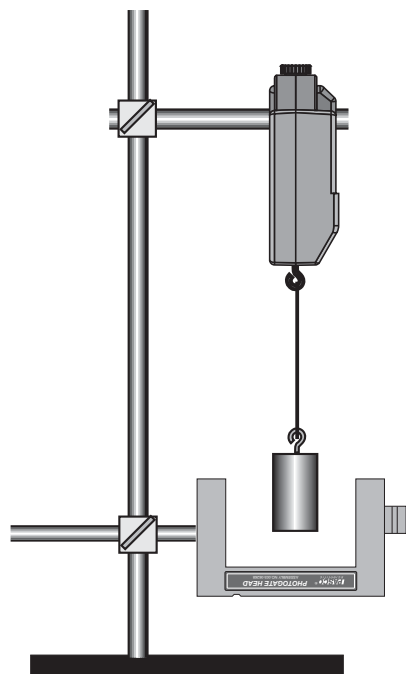

Analyzing the Data

1. Click on the Graph Display to make it active. Rescale the Graph axes to fit the data.

- In *DataStudio*, click on the ‘Scale to Fit’ button ().

2. Find the maximum centripetal force and corresponding velocity value.

In *DataStudio*, click the Force vs. Time plot to make it active. Click the ‘Smart Tool’ button (.

- Move the Smart Tool to the first trough in the plot of Force versus Time and read the value of force. Record the absolute value in the Data Table in the Lab Report section.
 - Click on the plot of Velocity vs. Time and click on the Smart Tool button. A second Smart Tool will appear. Place the tool at the velocity point that corresponds in time to the trough you measured in the plot of centripetal force. Record the value of speed in the Data Table.
3. Repeat the data analysis process for four more troughs on the plot of centripetal force. Record the maximum centripetal force and the corresponding speed in the Data Table in the Lab Report section.
4. For each value of speed you measured, calculate the centripetal force using the mass, speed, and length of the pendulum. Record the calculated value of centripetal force in the Data Table.
5. Calculate the percent difference between the measured centripetal force and the calculated centripetal force for each set of points. Record the percent differences in the Data Table.

Record your results in the Lab Report section.

Lab Report - Activity P26: Centripetal Force on a Pendulum**What Do You Think?**

What are the factors that affect the centripetal force on a pendulum bob as the pendulum swings back and forth? Does the centripetal force depend on how fast the pendulum bob is swinging?

Data Tables

Item	Value
Diameter	
Mass	
Length	

Points	F_c , measured (N)	v (m/s)	F_c , calculated (N)	% difference
1				
2				
3				
4				
5				

Questions

1. How do your measured values of centripetal force compare to the calculated values of centripetal force?

2. What are possible reasons for the differences between the measured and calculated values of centripetal force?

Optional

- Try a different mass value for the pendulum bob or a different length for the pendulum or change the speed of the pendulum and repeat the data recording process.

Optional Data Tables

Item	Value
Diameter	
Mass	
Length	

Points	F_C , measured (N)	v (m/s)	F_C , calculated (N)	% difference
1				
2				
3				
4				
5				

Questions

1. How do your measured values of centripetal force compare to the calculated values of centripetal force?

2. How do the centripetal force values in the optional activity compare with the values from the original activity?