

Experiment 3: Ohm's Law

EQUIPMENT NEEDED:

- AC/DC Electronics Lab Board: Wire Leads
- D-cell Battery
- Multimeter
- Graph Paper

Purpose

The purpose of this lab will be to investigate the three variables involved in a mathematical relationship known as Ohm's Law.

Procedure

- ① Choose one of the resistors that you have been given. Using the chart on the next page, decode the resistance value and record that value in the first column of Table 3.1.
- ② **MEASURING CURRENT:** Construct the circuit shown in Figure 3.1a by pressing the leads of the resistor into two of the springs in the Experimental Section on the Circuits Experiment Board.

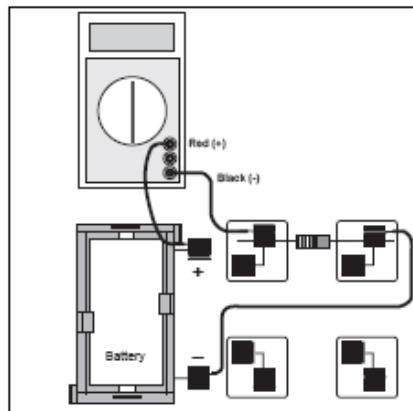

Figure 3.1a

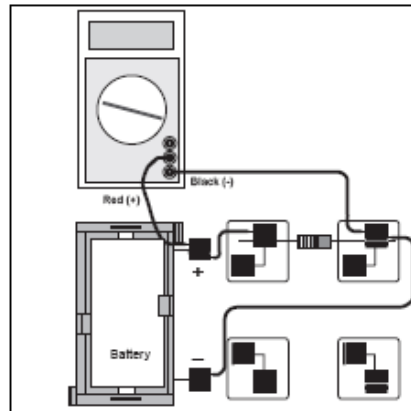

Figure 3.1b

- ③ Set the Multimeter to the 200 mA range, noting any special connections needed for measuring current. Connect the circuit and read the current that is flowing through the resistor. Record this value in the second column of Table 3.1.
- ④ Remove the resistor and choose another. Record its resistance value in Table 3.1 then measure and record the current as in steps 2 and 3. Continue this process until you have completed all of the resistors you have been given. As you have more than one resistor with the same value, keep them in order as you will use them again in the next steps.
- ⑤ **MEASURING VOLTAGE:** Disconnect the Multimeter and connect a wire from the positive lead (spring) of the battery directly to the first resistor you used as shown in Figure 3.1b. Change the Multimeter to the 2 VDC scale and connect the leads as shown also in Figure 3.1b. Measure the voltage across the resistor and record it in Table 3.1.
- ⑥ Remove the resistor and choose the next one you used. Record its voltage in Table 3.1 as in step 5. Continue this process until you have completed all of the resistors.

Data Processing

- ① Construct a graph of Current (vertical axis) vs Resistance.
- ② For each of your sets of data, calculate the ratio of Voltage/Resistance. Compare the values you calculate with the measured values of the current.

Table 3.1

Resistance, Ω	Current, amp	Voltage, volt	Voltage/Resistance

Discussion

- ① From your graph, what is the mathematical relationship between Current and Resistance?
- ② Ohm's Law states that current is given by the ratio of voltage/resistance. Does your data concur with this?
- ③ What were possible sources of experimental error in this lab? Would you expect each to make your results larger or to make them smaller?

Reference

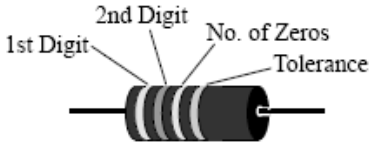
Black	0		<u>Fourth Band</u>	
Brown	1		None	$\pm 20\%$
Red	2		Silver	$\pm 10\%$
Orange	3		Gold	$\pm 5\%$
Yellow	4		Red	$\pm 2\%$
Green	5			
Blue	6			
Violet	7			
Gray	8			
White	9			

Resistance R_{cc} (Color Value Tolerance)	Resistance R_{OM} (Ohm-meter value)	Resistance R_M (Voltage/Current)	% Error (STD = R_{cc})	%Error (STD = R_{OM})

4. How does your % error, using R_{cc} as the standard, compare with the tolerance indicated on the resistor?

5. How does your % error, using R_{OM} as the standard, compare with the tolerance indicated on the resistor?

6. Which value of resistance is more accurate, R_{cc} or R_{OM} ?